

Technical data

Capacity*	120 Kg.
Hinge height	190 mm
Width shutter side	31 mm
Width frame side	31 mm
Depth shutter side	35,5 mm
Depth frame side	29,5 mm
Door opening angle	180°

Side adjustment	± 1,5 mm
Height adjustment	± 3 mm
Depth adjustment	± 1 mm

* Tested with 90x210 cm doors - For more information on the number of hinges to be used according to the weight and dimension of the door, please see the loading charts available on the website www.otlav.it.

Technical features

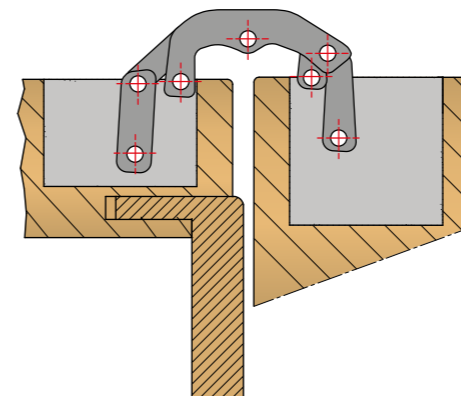

- Movement on **7 junction fulcrums** equipped with bearing in plastic HT with high resistance and long life.
- Equipped with **3-way adjustments** that can be settled by means of just one 4 mm hex-spanner. Once installed, the door has natural sinking, Invisacta hinge allows to set the door back to the start position.
- **The hinge can be fitted with door closing devices.**
- Outer casings protect the inner junction fulcrums against rubble coming from door installation works.
- The clamping screws, placed in the outer casings, are not used for hinge adjustment, therefore they remain stable for a long time.
- **CE certified** - according European Assessment Document 020001-01-0405.
- The hinge meets the **anti-burglary** criteria according European Assessment Document 020001-01-0405.
- **Fireproof certified 90'** according UNI-EN 1634-1.
- Reversible
- Material of levers: aluminum.
- Material of casing: zamak.
- **Caps** available to conceal the screws.

Finishing



IN310190V703
Satinized Silver Plated



IN310190VN03
Satinized Nickel Plated



IN310190N03
Matt Black Plastified



IN310190P03
White Matt RAL 9016

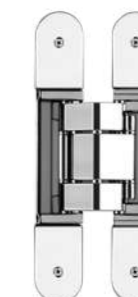

IN310190VD03
Polished Chrome



IN310190VO03
Polished Gold

**OTHER KIND OF FINISHING
AVAILABLE ON REQUEST**