

Technical data

Capacity*	80 Kg.
Hinge height	120 mm
Width shutter side	30 mm
Width frame side	30 mm
Depth shutter side	30 mm
Depth frame side	21 mm
Door opening angle	180°
Side adjustment	± 1 mm
Height adjustment	± 2 mm
Depth adjustment	± 1 mm

* Tested with 90x210 cm doors - For more information on the number of hinges to be used according to the weight and dimension of the door, please see the loading charts available on the website www.otlav.it.

PATENTED

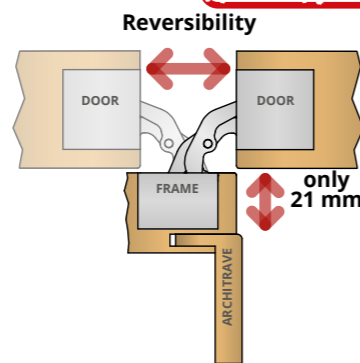

IN303 hinge allows at the same time:
Reversibility of the door with hinge mounted in the center of the door thickness.
No need to cut the architrave thanks to only 21 mm of frame slot depth.
 Patented EP-B2719851.

Technical features

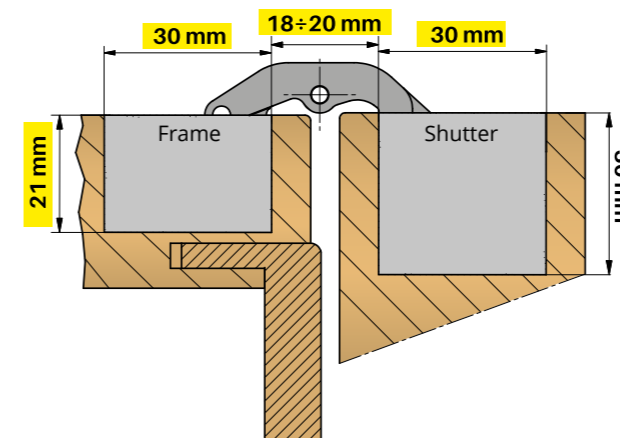

- A 21 mm depth slot on the frame side makes it unique and enables its **perfect integration in reduced spaces**. No need to cut the architrave which can be flush mounted.
- The hinge is reversible, if mounted in the center of the door thickness, allows the **reversibility of the door**, thus enabling the optimization of the stock and logistics at installation.
- Movement on **7 junction fulcrums** equipped with bearing in plastic HT with high resistance and long life.
- Equipped with **3-way adjustments** that can be settled by means of just one 3 mm hex-spanner. Once installed, the door has natural sinking, Invisacta hinge allows to set the door back to the start position.
- Outer casings protect the inner junction fulcrums against rubble coming from door installation works.
- The clamping screws, placed in the outer casings, are not used for hinge adjustment, therefore they remain stable for a long time.
- **The hinge can be fitted with door closing devices.**
- Material of levers: aluminum.
- Material of casing: zamak.
- **CE certified** - according European Assessment Document 020001-01-0405
- **Fireproof certified 45'** according UNI-EN 1634-1
- **Aluminum caps** available to conceal the screws.

Finishing



Hinge **IN303120V702**
 Caps **GC300010J102**
 Satinized Silver Plated



Hinge **IN303120VN02**
 Caps **GC300010J205**
 Satinized Nickel Plated



Hinge **IN303120VO02**
 Caps **GC300010J005**
 Polished Gold



Hinge **IN303120VD02**
 Caps **GC300010VD02**
 Polished Chrome

OTHER KIND OF FINISHING AVAILABLE ON REQUEST